

Thank you for your choice of the Bachmann Branchline Class 55 'Deltic' diesel locomotive.

General

The mechanism of this model requires running in (without a load) for approximately 1 hour in each direction at moderate speed to allow the gear train to bed in.

When required, sparingly lubricate the motor bearings using plastic compatible light oil and the gear train with model grease.

Bachmann Branchline locomotives are not suitable for use on track tighter than second radius (18 inches).

Body removal

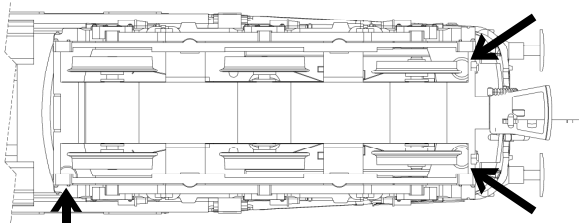

There are six screws, one by the corner of the fuel tank and one by each buffer, as indicated on the diagram

DCC Decoder fitting to DC model

This model has a 21-pin connector for a decoder.

Use either a decoder with matching fitting (for example Bachmann 36-554) or the Bachmann 36-559 8/21-pin adaptor to use a decoder with an 8-pin plug.

It is recommended to run a DC loco in first on a DC power supply before installing a decoder.

Carefully remove the blanking board and locate the decoder onto the pins on the PCB following the instructions included with the decoder: the decoder fits so that the contact block is uppermost with the decoder fitting towards the middle of the main loco PCB.

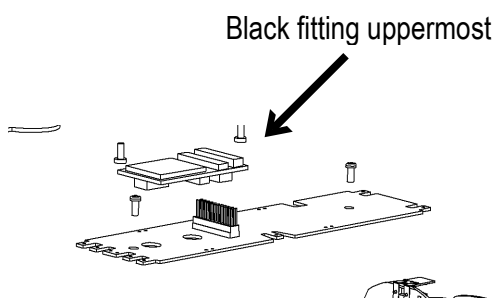

DCC Sound decoder fitting to DC model

There are loudspeaker connections on the main PCB, marked 'SP+' and 'SP-' that can be used when a sound decoder with a 21-pin connector is used. Follow any fitting instructions supplied with the decoder.

Control of lights with DCC

When using a decoder with the appropriate number of function outputs, the onboard lights can be controlled as follows:

F0 - Head lights / tail lights turned on / off

Location of 'add on' parts

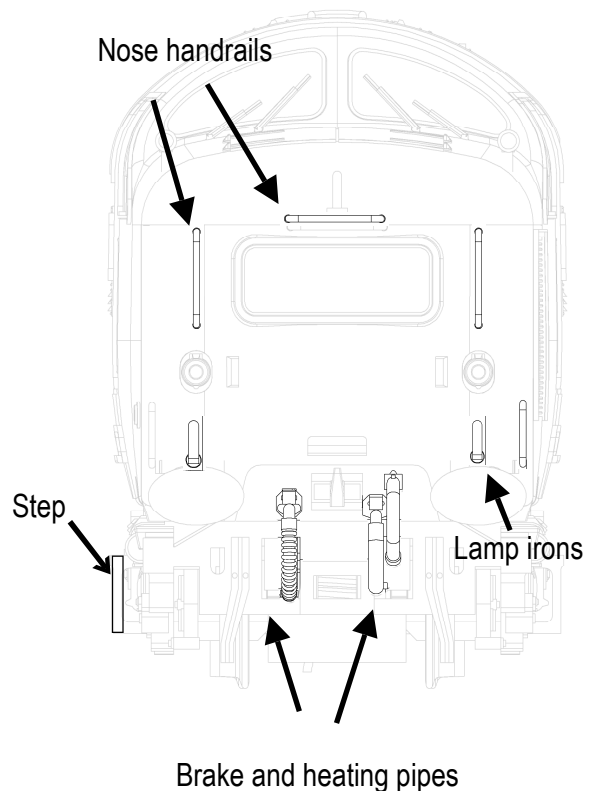

Additionally, the steps fit to the bogie beneath the cab doors.

Hints for best results

The operation of a DCC loco requires that the power to the model is not interrupted. Track, wheels and pickups should be kept clean and all rail joiners must give good connections between sections of track. Improved reliability of DCC performance may be obtained by deselecting DC operation of the model on the decoder. This is usually controlled by CV29, Bit 2

Replacement Parts

- 1 525-006 motor
- 2 525-018 PCB 21pin
- 3 525-009 driveshaft
- 4 525-013 underframe
- 5 525-013 bogie tower top
- 6 525-032 driving wheels (inner)
- 7 525-033 driving wheels (outer)
- 8 525-022 bogie
- 9 BL2007 drive cup
- 10 525-030 bogie frame
- 11 BL1998 coupling
- 12 525-015 LED board
- 13 525-016 motor bracket
- 14 525-014 buffer beam pack

When ordering parts please quote the catalogue number together with the livery of the model (if appropriate) and number of the part required.

Parts are subject to availability.

Packets of couplers (item 36-030) suitable for this model are available from retailers

Bachmann Europe Plc

Moat Way
 Barwell
 Leicestershire
 LE9 8EY
 01455 841756
www.bachmann.co.uk

The model should be handled carefully as it has many finely detailed parts. It is not suitable for persons under 14 years.

