

5. DCC Sound - Installing DCC Sound (Continued)

fig.12

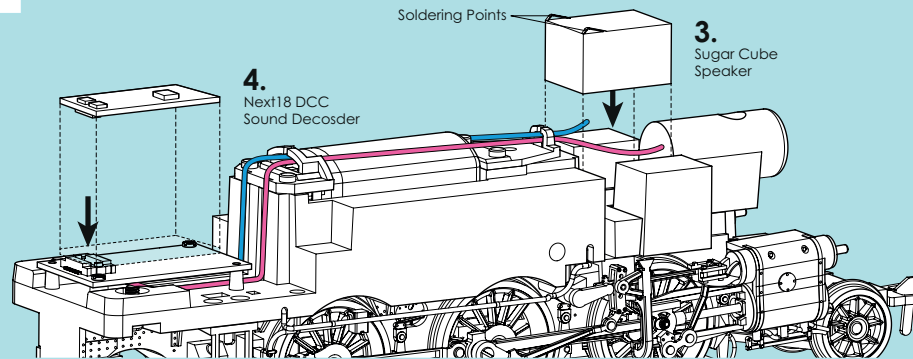

3. Fit your Sugar Cube Speaker (no bigger than 15 x 11 x 9mm) into the space shown and solder to the corresponding '+' & '-' wires that were fitted earlier.

4. Push-fit the Next18 DCC Sound Decoder into the socket on the PCB board as shown.

6. DCC On Board Models

Your model has been factory-fitted with a **Zimo MX618 N18 DCC decoder**. The instruction manual for this decoder is available for free download from the Zimo website at www.zimo.at

7. Spare Parts

Selected spare parts are available from the Bachmann Europe Service Department. For further information and enquiries please contact the Service Department directly by email on service@bachmann-europe.co.uk or by phone **01455 245575**.

8. Warranty

This product has a Warranty for 12 months from the date of purchase against faulty materials or workmanship subject to the following conditions. During this period such defects that occur will be repaired or defective parts replaced free of charge.

1. This Warranty applies only if the item was purchased from an authorised retailer of Bachmann Europe plc ('Bachmann') within the European Union / EEA. This Warranty does not confer any rights other than those expressly set out above and does not cover any claims for consequential loss or damage. The Warranty is offered as an additional benefit and does not affect your statutory rights as a consumer.

2. For claims under this Warranty, in the first instance the product must be returned to the retailer with evidence of the purchase date in the form of retailer receipt/invoice accompanied by a letter or Service Request form setting out the date and place of purchase, giving a brief explanation of the problem that has led to the claim. It is essential that the claim reach the retailer on or before the last day of this Warranty period. Late claims will not be considered.

3. This Warranty is only available to the original retail purchaser of this product and is non-transferable.

4. The Warranty does not extend to cover damage resulting from misuse or careless handling, accidental damage, wear and tear, or use on a voltage supply other than that stamped on the product.

5. The Warranty may be considered void if repairs have been attempted other than by Bachmann staff.

6. The Warranty is on the original product in its entirety and does not extend to individual components removed from the product. In respect of train sets the warranty applies to motorized units and controllers only.

7. If Bachmann chooses to replace a product it will be with the nearest appropriate model of its choice.

8. Bachmann reserves the right to decline service to any model that has been fitted with a decoder after manufacture.

9. Bachmann will not be held responsible for damage to or loss of an after market decoder fitted to a model submitted for service under the Warranty.

10. The fitting of a Bachmann decoder with a current Warranty shall not be deemed to change the position regarding a product that is otherwise outside its own Warranty. It may be necessary to change decoder settings during service.

11. Bachmann's liability under this Warranty will in no case exceed the price paid for the product as originally manufactured.

Bachmann Europe Plc
Moat Way, Barwell, Leicestershire, LE9 8EY, England.
www.bachmann.co.uk



Ivatt Class 2MT Tank Locomotive Owner's Information

Welcome

Many thanks for purchasing one of our **Bachmann Branchline Ivatt Class 2MT Tank Locomotives**. A lot of care was taken producing your model and we hope you enjoy it for many years to come.

Please note: This model has been designed to run on curves of **no less than 2nd Radius (438mm)**. We recommend that you don't use anything smaller as this may result in the model derailling.

For best results don't use with Electronic Track Cleaners or Feedback Controllers.

1. Accessories

Although our models are highly detailed and ready to run straight from the box we also supply optional accessories to be fitted by the owner if they wish. Some of the accessories should only be fitted for static display as they may affect coupling or running quality, these parts will be labelled as such below.

Please note: PVA based adhesive should be used for the fitting of accessories.

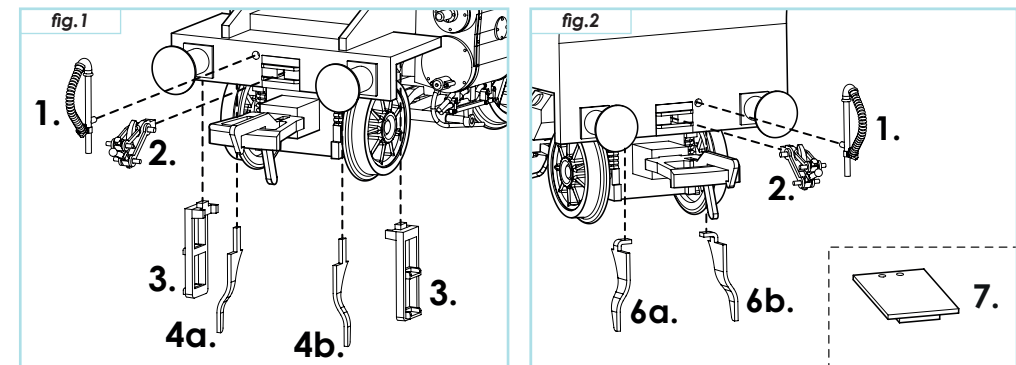

- | | | |
|---------|----------------------------|---|
| 1 | Vacuum pipes | |
| 2 | Screwlink coupling | - only fit if standard coupling has been removed to avoid derailling. |
| 3 | Front chassis steps | - use only on 3rd radius (505mm) curves or larger. |
| 4a & 4b | Front guard irons | - use only on 3rd radius (505mm) curves or larger. |
| 5a & 5b | Rear guard irons | - use only on 3rd radius (505mm) curves or larger. |
| 6 | DCC Blanking Plate | - only included in DCC Fitted models. |

2. Running-in

It is necessary that this locomotive is 'run-in' to allow the mechanism and gears to settle. This requires the model to be run without a load (wagons, coaches, etc.) for 30mins in each direction at half speed.

3. Lubrication

All Bachmann Branchline locomotives are supplied ready lubricated and can be used straight from the box. Over time your locomotive will require some additional lubrication, when will depend on the frequency of use and storage so please inspect your model on a regular basis.

If the driving wheel axles appear dry and no lubricant is visible, (where shown in **fig.3**) it would be advisable to lubricate your model.

Please note: A plastic compatible lubricant is required. Suitable products from both the Bachmann Trains & Woodland Scenics ranges are available from your local Bachmann retailer.

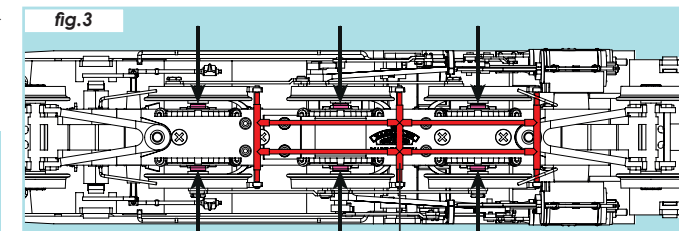

8. Brake Rodding Accessory

3. Lubrication (Continued)

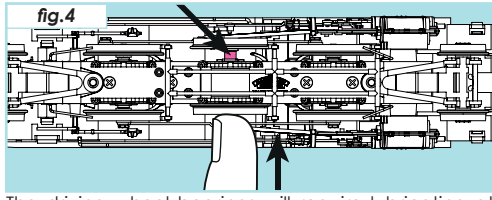

The driving wheel bearings will require lubricating at both ends, to do this simply push the set of wheels to one side and apply a single drop of plastic compatible lubricant to the exposed axle. Then repeat on the other side.

Motor Bearing Lubrication

The motor bearings will also require lubricating. A small amount of disassembly is required and is shown in figure 6, 7 & 8.

Begin by removing the body (fig.6).

If the motor bearing shaft appears dry, apply one drop of lubricant to each end of the shaft. (Shown in pink in Fig. 7 & 8)

Rear Motor Bearing Lubrication.

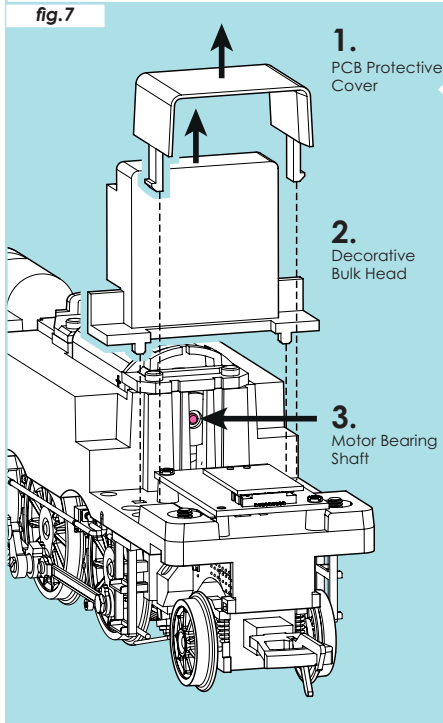

1. Remove the PCB protective cover.
2. Remove the decorative bulk head of the firebox.
3. Lubricate the rear end of the motor bearing shaft.

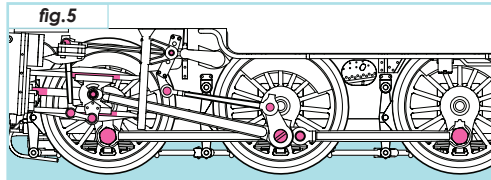

Oiling will also be required to all moving parts of the connecting rods and valve gear. Apply a single drop of oil to the areas indicated in pink above (fig.5) and the corresponding points on the other side.

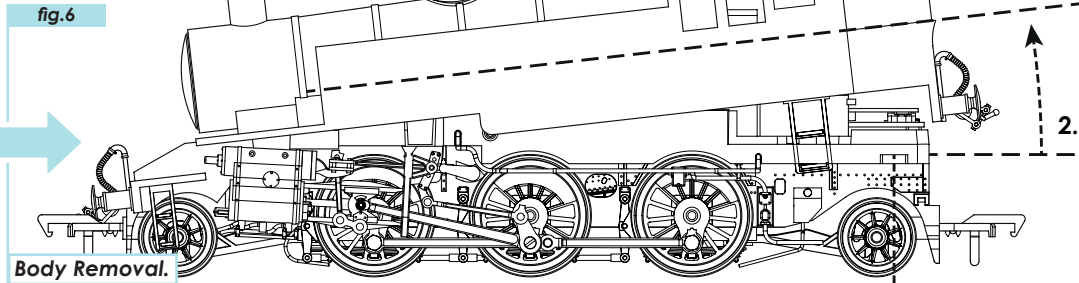

Body Removal.

1. Unscrew the two securing screws on the underside of the chassis at the cab end of the locomotive.
2. Lift the body off from the cab end of the locomotive. The front is secured by a locating lip on the chassis that corresponds with a slot on the body.

Front Motor Bearing Lubrication.

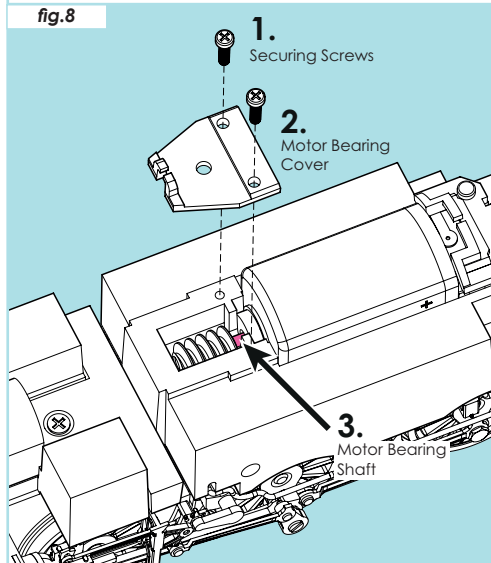

1. Remove screws.
2. Remove the motor bearing cover.
3. Lubricate the front end of the motor bearing shaft.

4. DCC Decoder - Fitting a Next18 DCC Decoder

Digital Command Control (DCC) allows for greater functionality and control over the locomotives on your layout: such as the simultaneous control of speed & direction of multiple locomotives and enables the use of DCC controlled track, points and other DCC Decoder fitted accessories. DCC also allows the addition of DCC Sound which brings a whole new level of realism to your model railway.

1. Remove the PCB protective cover.
2. Remove the DCC blanking plate.
3. Push fit a Next18 DCC decoder into the socket on the PCB board as shown.

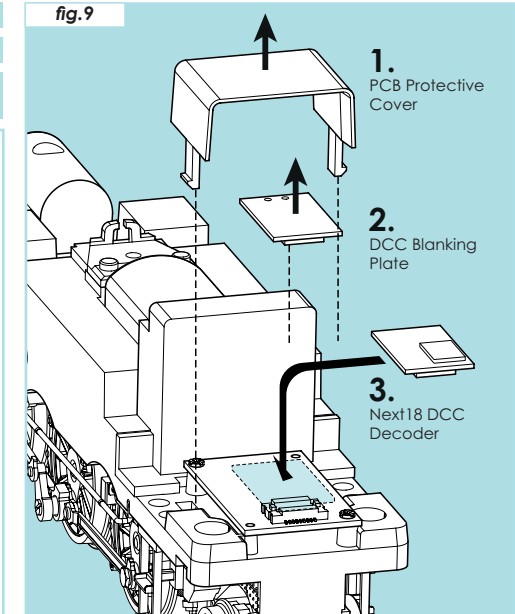

5. DCC Sound - Installing DCC Sound

The following equipment is required for DCC Sound.

- 1 x Next18 DCC Sound Decoder (pre-programmed with the relevant sound file of your choice).
- 1 x 'Sugar Cube' Speaker no bigger than 15 x 11 x 9mm.
- 2 lengths of suitable wire to connect the speaker to the PCB Board.

Please note: It's recommended that the DCC Decoder and Speaker are both from the same manufacturer and the speaker specifications are compatible with the decoder. Please consult your retailer for advice.

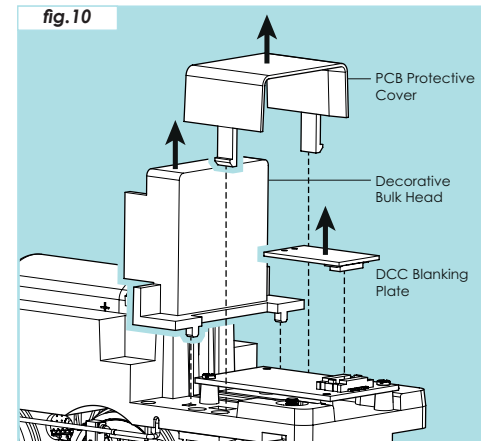

1. Remove the PCB protective cover, DCC Blanking Plate & Decorative Bulk Head (fig.10).

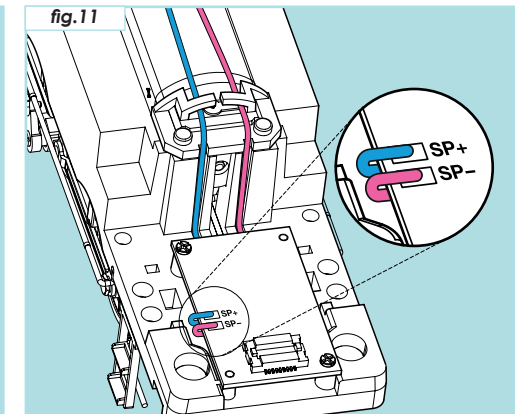

2. Solder the two wires to the soldering pads on the PCB board marked 'SP+' & 'SP-' and fit into the grooves and clips provided (fig.11).