

Welcome

Many thanks for purchasing one of our **Bachmann Branchline** BR Mk2F Coaches. A lot of care was taken producing your model and we hope you enjoy it for many years to come.

Please note: This model has been designed to run on curves of **no less than 2nd Radius (438mm)**. We recommend that you don't use anything smaller as this may result in the model derailing.

1. Accessories

Although our models are highly detailed and ready to run straight from the box we also supply optional accessories to be fitted by the owner if they wish. Some of the accessories should only be fitted for static display as they may affect coupling or running quality, these parts will be labelled as such below.

Please note: PVA based adhesive should be used for the fitting of accessories. This allows for the removal of an accessory without damaging the model.

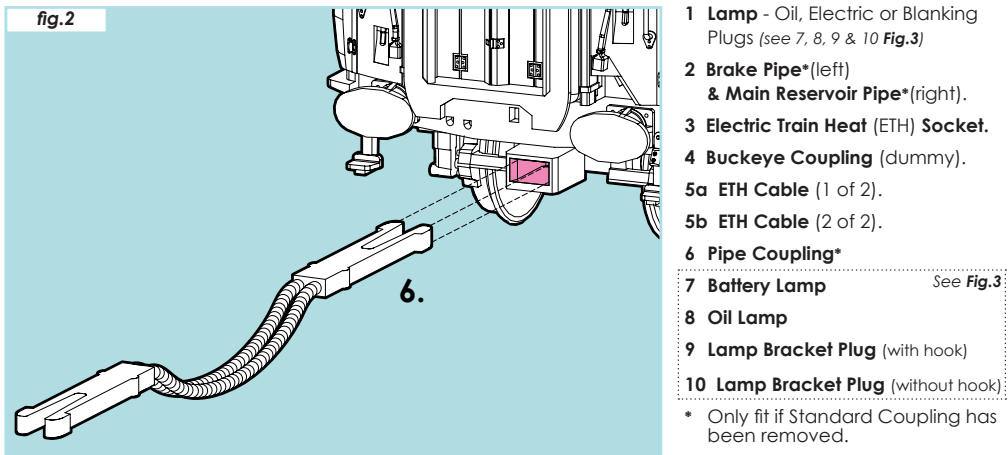
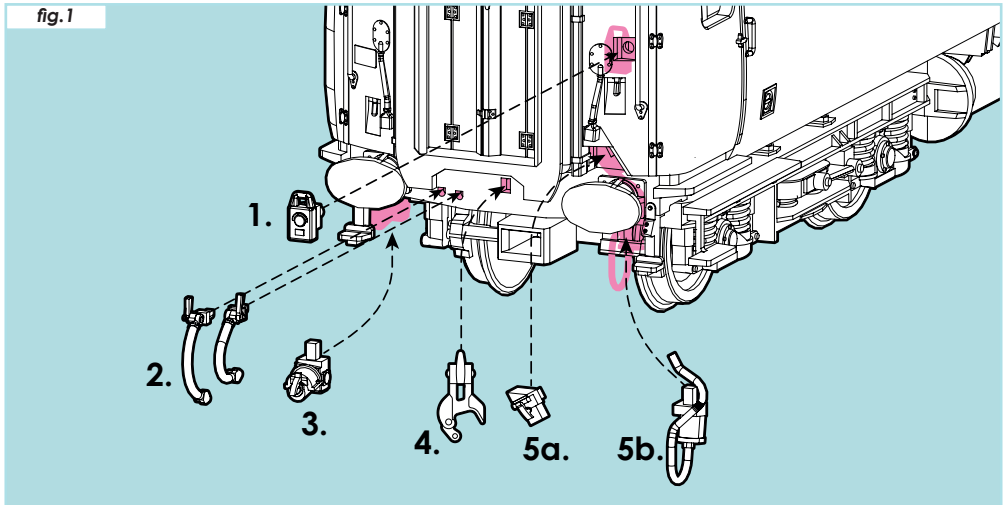

2. Tail Lamps & Blanking Plugs

Our FO, TSO, BSO & RFO all come with a choice of Tail Lamps and Blanking Plugs. There are two different types of lamps, Battery (7) & Oil (8), and two Blanking Plugs (9 & 10) see **Fig.3**. Oil lamps were in use until the Late 1980s and battery powered lamps were introduced in the early '80s. The older oil lamps gave a constant red light and were replaced by the later battery lights which flashed on and off to increase visibility.

If you intend to run your coach in the middle of a set and don't wish to use the end lights there are two blanking plugs to choose from, one with a hook to aid removal (9) and one without (10). **Please note, if you fit the blanking plug without the hook then you will struggle to remove it.**

A special tool has been provided to help remove the blanking plug with the hook (**Fig.4**).

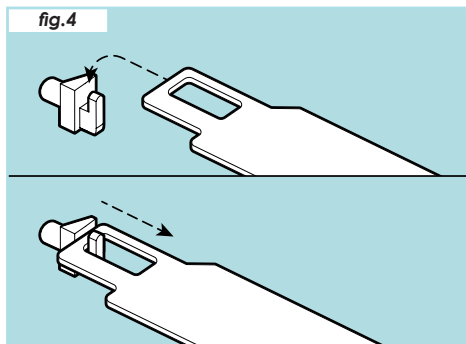
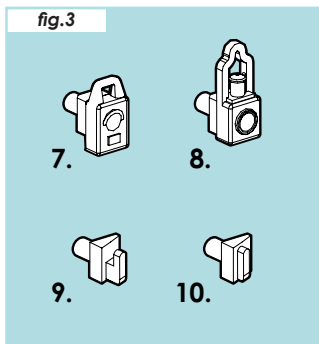

Bachmann Europe Plc
Moat Way, Barwell, Leicestershire, LE9 8EY, England.
www.bachmann.co.uk